

ELEVATIONS IN FEET
ALL OTHER DIMENSIONS IN METRES

AERODROME OBSTACLE CHART

TYPE - A (OPERATING LIMITATIONS)

INDIA / PATNA
J.P.N. INTL. AIRPORT, PATNA / RWY25

MAGNETIC VARIATION 0° (2010)

RWY 07 / 25

DECLARED DISTANCES

RWY 07		RWY 25
2072	TAKE-OFF RUN AVAILABLE (TORA)	2072
2072	TAKE-OFF DISTANCE AVAILABLE (TODA)	2072
2072	ACCELERATE-STOP DISTANCE AVAILABLE (ASDA)	2072
1677	LANDING DISTANCE AVAILABLE (LDA)	1938

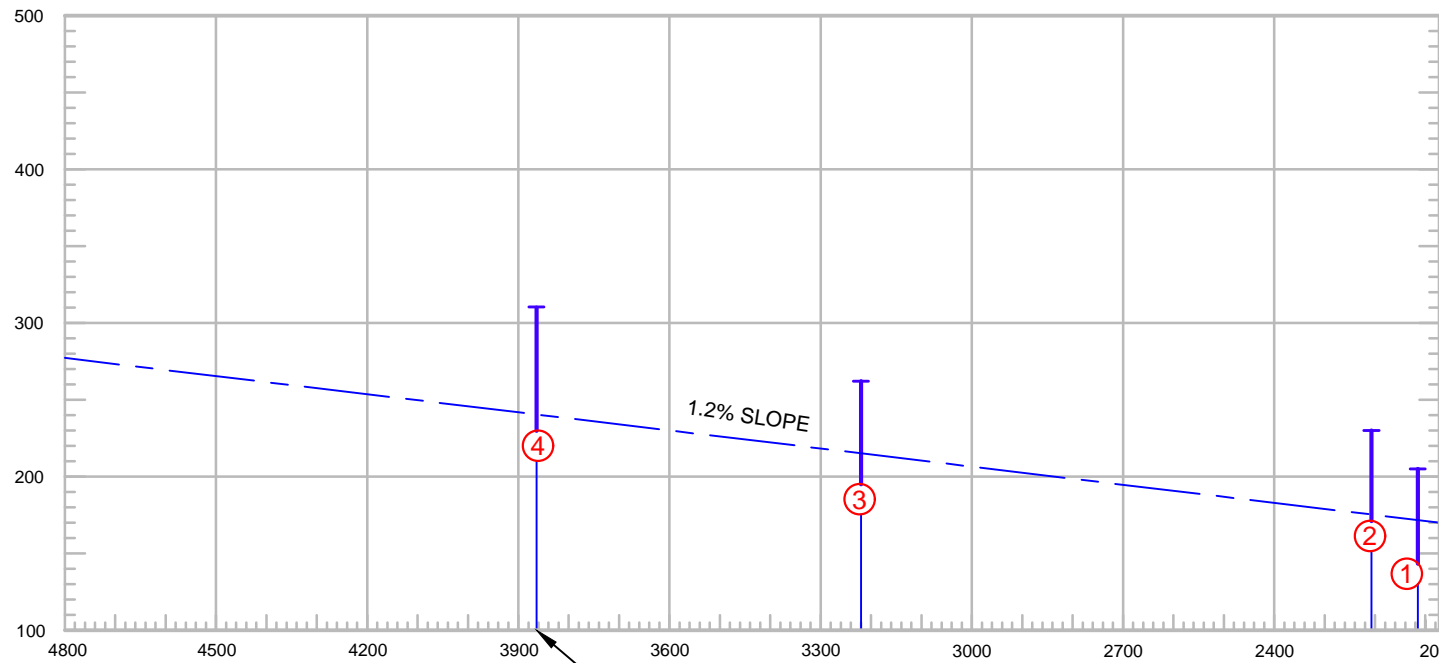

NO SIGNIFICANT OBSTACLES
BEYOND THIS POINT

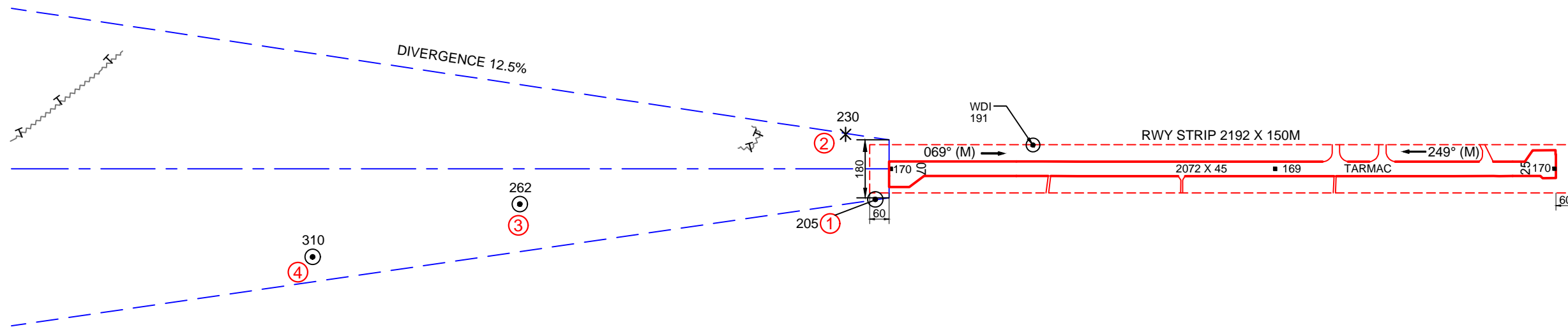
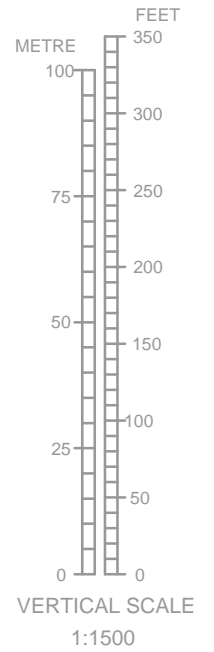

HORIZONTAL SCALE 1:15000

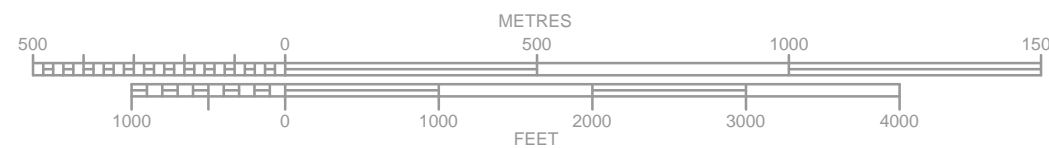

ORDER OF ACCURACY

HORIZONTAL - 3.0m
VERTICAL - 1ft.

NOTES:

- The objects that have been shielded due to presence of other higher objects have not been shown in this chart.
- Datum - All Elevations are AMSL.
- Periphery road without traffic is no obstacle.
- Consult Notam for latest information.
- Rwy directions rounded to nearest degree. (Magnetic)
(in degree minute: Rwy 07/25 = 068°40'/248°40')(2010)
(in degree minute: Rwy 07/25 = 068°45'/248°45')(2016)
- Magnetic variation rounded to nearest degree 0°15'W
Annual rate of change 01'E (2010).
- All obstacles shown in this chart are based on aeronautical obstacle survey July 2016.
- Chart prepared based on (DGCA CAR) section 9AS & ATM series 'G' Part 1 Revision 4, 26th Aug, 2014.

AMENDMENT RECORD

NO.	DATE	ENTERED BY

LEGEND		
NAME	PLAN	PROFILE
IDENTIFICATION NUMBER	①	
POLE, TOWER, ANTENNA	⊙	
TREE OR SHRUB	*	
HIGH TENSION LINE	~	
RWY ELEV.(SPOT)	■ 169	

AERONAUTICAL INFORMATION UPTO - NOV. 2017

वैमानिक सूचना - नवम्बर 2017 तक

COMPILED BY : CARTO - AIRPORTS AUTHORITY OF INDIA

संग्रहित किया : कार्टो, भारतीय विमानपत्तन प्राधिकरण

CHART NO. AAI/17-OBS/CARTO/2017

चार्ट सं. भा.वि.प्रा./17-अव./कार्टो/2017