

# AERODROME OBSTACLE CHART

INDIA / DELHI

ELEVATIONS IN FEET  
ALL OTHER DIMENSIONS IN METRES

TYPE - A (OPERATING LIMITATIONS)

CONSULT NOTAM FOR LATEST INFORMATION

IGI AIRPORT / RWY 28

MAGNETIC VARIATION 0° 45' E (2010)

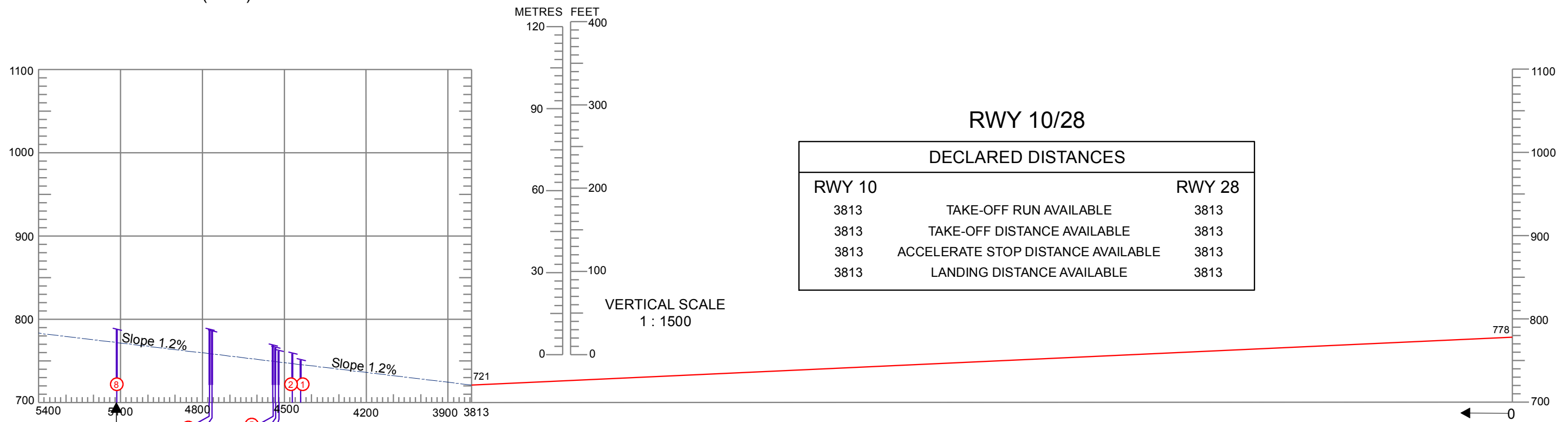

NO SIGNIFICANT OBSTACLES BEYOND THIS POINT

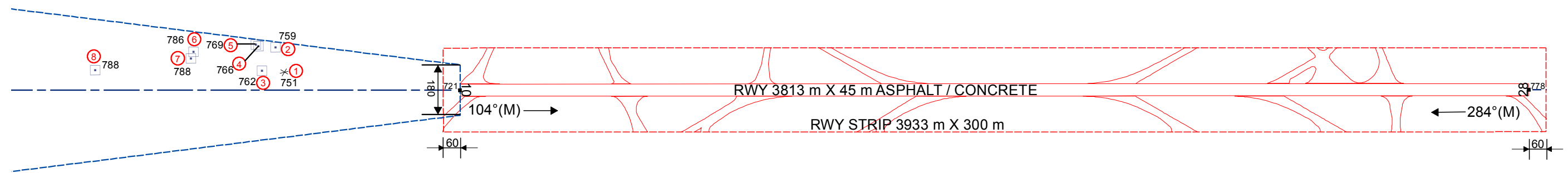

HORIZONTAL SCALE 1 : 15000

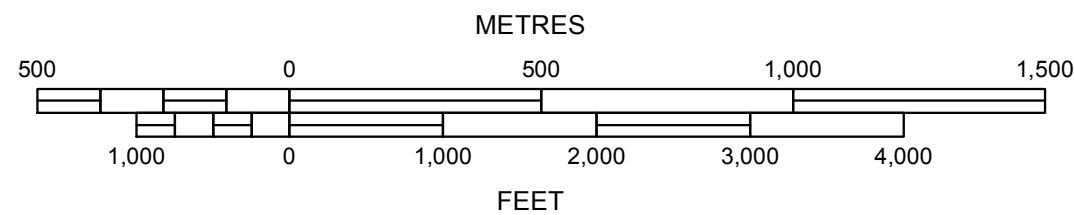

ORDER OF ACCURACY  
HORIZONTAL : 3.0 m  
VERTICAL : 1.0 ft

**NOTES:**

- The objects that have been shielded due to presence of other higher objects have not been shown in this chart.
- Datum - All Elevations are EGM2008.
- Periphery road without traffic is no obstacle.
- Consult Notam for latest information.
- RWY direction rounded to nearest degree. (Magnetic) (In degree minute : RWY 10/28 = 103°59'/283°59' ) (taken upto 2016)
- Considering App.Lights and LLZ Antenna as frangible are not taken in this chart.
- All obstacles shown in this chart are based on aeronautical obstacle Survey of February, 2016 to June,2016 and DIAL Itr no.4800122788 DT 28 Oct 2015.

**LEGEND**

	PLAN	PROFILE
IDENTIFICATION NUMBER	①	—
TREE	✳	—
BUILDING	□	—
RWY ELEV. (SPOT)	•721	—

**AMENDMENT RECORD**

NO.	DATE	ENTERED BY