

INSTRUMENT
APPROACH
CHART

AERODROME ELEV 760ft.
HEIGHTS RELATED TO
THR RWY 34-ELEV 756ft

APP.121.15
TWR.124.35

AMRITSAR
INDIA
VOR RWY34

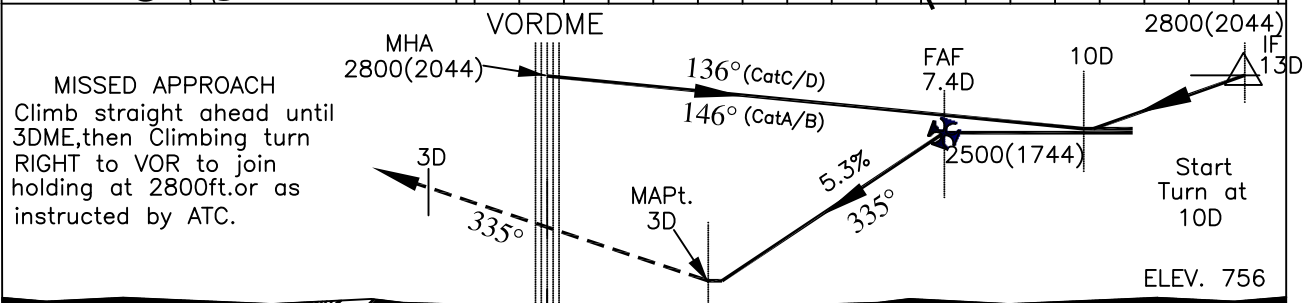
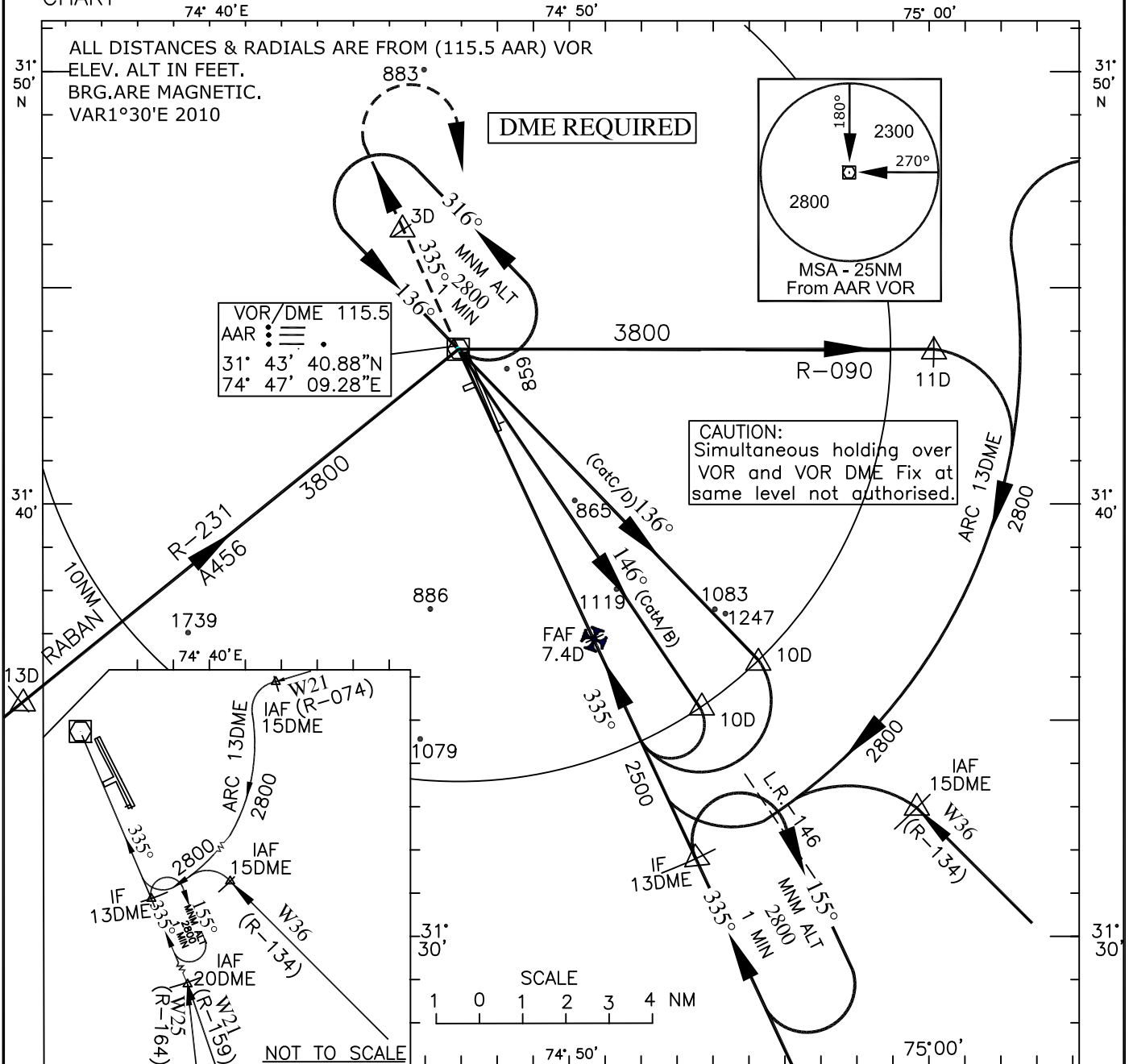

NAUTICAL MILES FROM THR RWY 34		0 1 2 3 4 5 6 7 8 9 10								
O C A (H)		Distance (AAR) /Altitude information								
Category of Aircraft	A/B	C/D	Distance (NM)	7.4D	7D	6D	5D	4D		
Straight-in	1160(400)	1160(400)	Altitude (ft.)	2500	2380	2060	1730	1410		
		Rate of Descent/Ground speed information								
Visual Circling	1370(610)	1520(760)	Ground speed (kt.)	80	100	120	140	160	180	
				Rate of descent (ft/min)	420	525	630	735	845	950
DRG. NO. AAI/11-IALC/2012/18.08.2023										